

M-410iB™ Series

Basic Description

The M-410iB series is FANUC Robotics' latest-generation palletizing industrial robot. The unit is engineered for precision high-speed/high-payload operation, user-friendly setup, and maximum reliability supported by our extensive service and parts network. The M-410iB is a four-axis, electric servo-driven robot with an integrated mechanical and control unit designed for a wide variety of manufacturing and palletizing system processes.

M-410iB, the Solution for:

- Case palletizing
- Bag palletizing
- Depalletizing
- Layer handling
- Press tending
- Machine load/unload
- Part transfer

Benefits

- Fastest cycle times and highest payload in robot class.
- 20 cycles/min. case palletizing at 100 kg.
- 27 cycles/min. bag palletizing at 100 kg.
- Large allowable wrist inertias meet a variety of heavy handling challenges.
- High performance motion yields fast cycle times and high throughput.
- Small footprint and integrated controller reduces required floor space.
- Ability to service multiple production lines with large working envelope.
- Unique hollow RV speed reducers simplify cable routing.
- Proven, reliable FANUC servo drives provide highest uptime and productivity.
- Able to operate in environments ranging from harsh to traditional factory floor.

Features Mechanical

- 4 axes of motion
- M-410iB/160: 160 kg payload capacity
- M-410iB/300: 300 kg payload capacity
- M-410iB/450: 450 kg payload capacity



- Dedicated pneumatic and electrical connections on J4 wrist to simplify user's end-of-arm tooling design, integration and communications (eight digital inputs/outputs, two 10 mm internal air lines).
- Adjustable J1 hard stops.
- Repeatability of ± 0.5 mm at full speed and full payload within entire work envelope.
- Direct-coupled drives on all axes result in higher reliability and reduced maintenance costs.
- Vertical articulation eliminates "elbow" interference issues related to SCARA robots.

Controller

- Quick change amplifier <5 min.
- Fast boot time <30 sec.
- Standard Ethernet port.
- PCMCIA software distribution.
- Easy connections to a variety of I/O, including a number of distributed I/O networks.

Software

- Supports industry leading PalletTool®/PalletPRO™ software packages (palletizing setup, simulation and operation software).
- Supports CollisionGuard™ by servo control to minimize damage to the robot, gripper, cases/bags and peripherals.
- Web-based software tools for

remote connectivity, diagnostics and production monitoring.

- Machine vision for robot guidance (e.g. vision guided depalletizing) and inspection.
- iPendant™, a color, Internet-ready teach pendant for even easier programming and custom cell user interface design.

Options

- Remote mount controller option with various robot connection cable lengths for flexible cabinet placement and optional track rated cables.
- Integrated auxiliary axes packages.
- Servo hand package utilizing standard six-channel robot servo amp.
- Fan cooling for J1, J2 and J3 motors in high-duty applications.
- iPendant is also available with touch screen support.
- Monochrome pendant available.
- FANUC's iRVision system delivers high performance 2-D and 3-D machine vision capabilities with FANUC reliability. Additional option for Error Proofing can provide integrated vision based capabilities to check for product completeness before product is packaged or further operations are performed.

FANUC
Robotics

M-410iB/160/300 Dimensions

Isometric

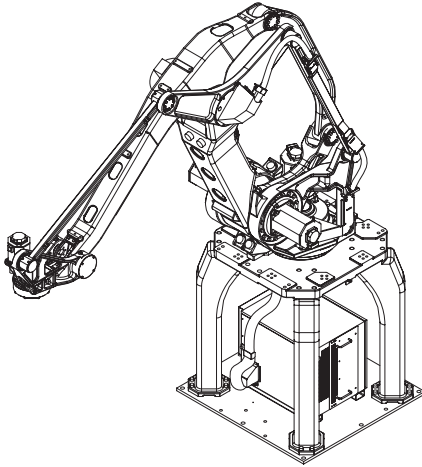

Wrist

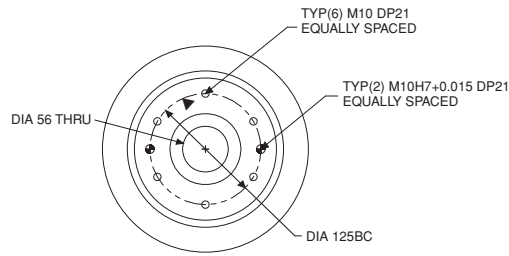

Footprint

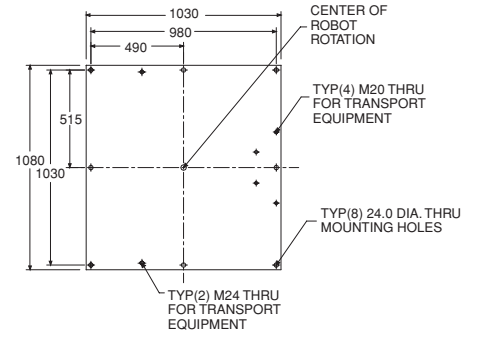

Top

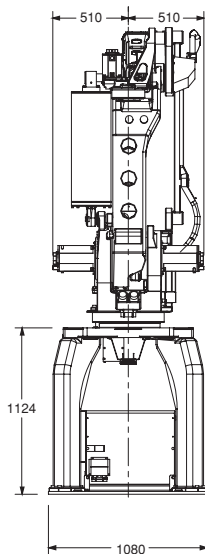
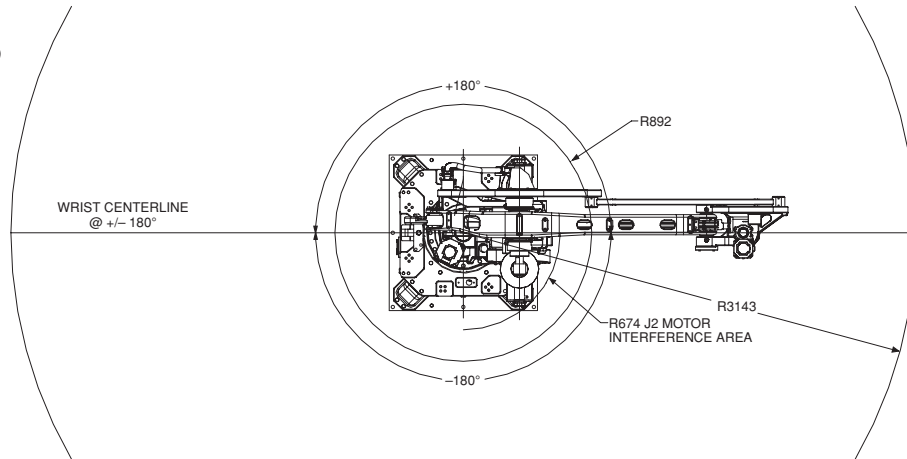

Front

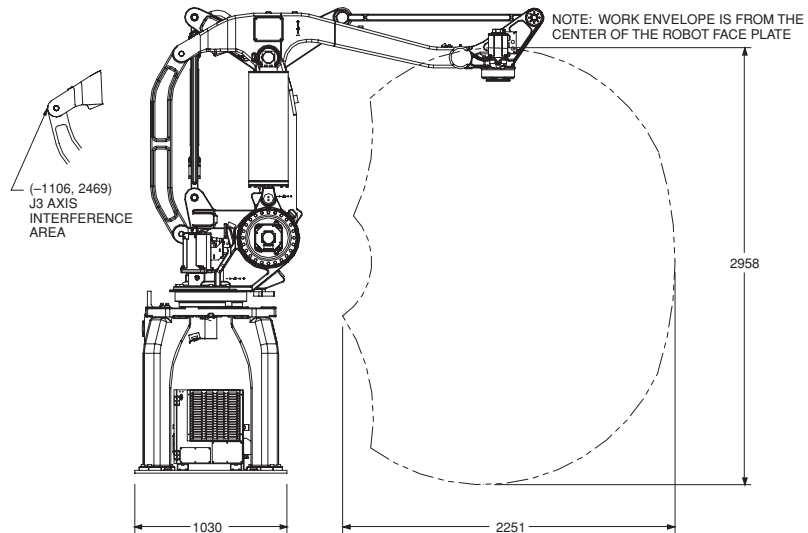

Side

Note: Dimensions are shown in millimeters. Detailed CAD data are available upon request.

M-410iB/450 Dimensions

Isometric

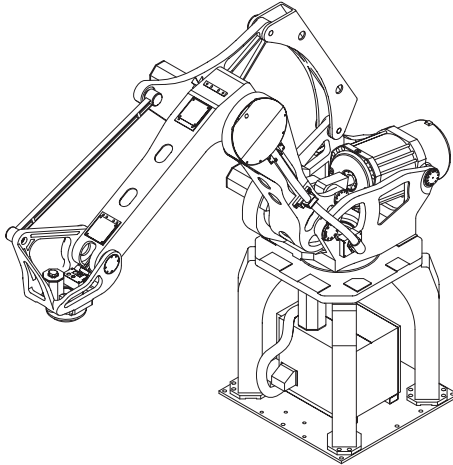

Wrist

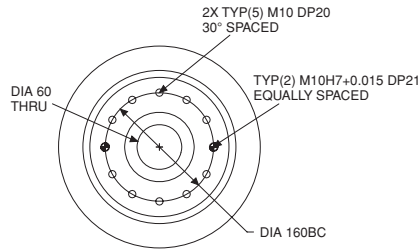

Footprint

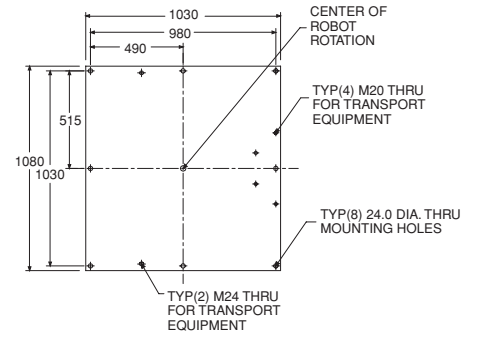

Top

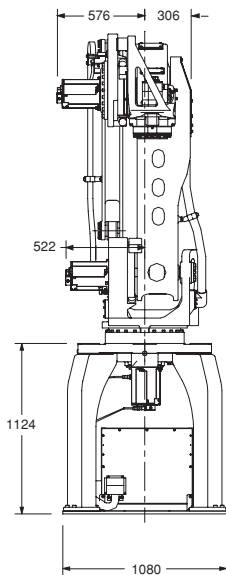
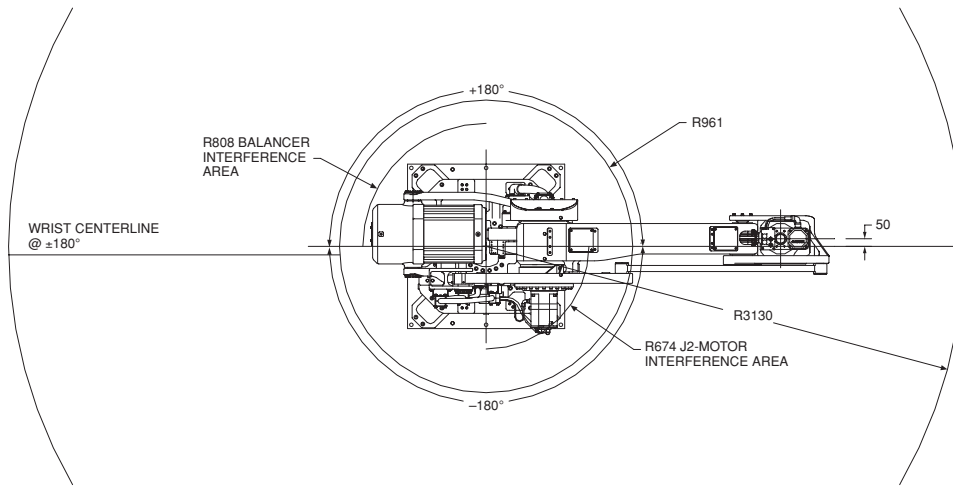

Front

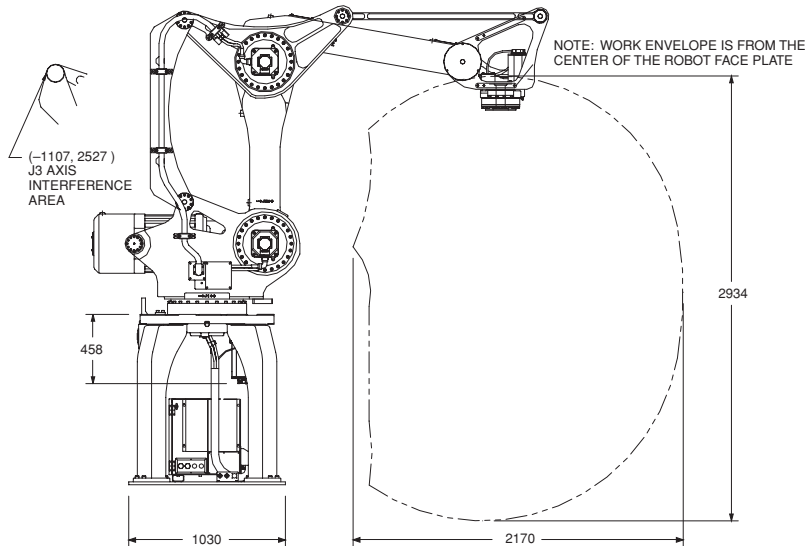

Side

Note: Dimensions are shown in millimeters. Detailed CAD data are available upon request.



Corrugated Case Palletizing

Over 2,000 M-410i units installed in a variety of palletizing and part handling applications.



Layer Palletizing



Mixed Load Palletizing

M-410i/B Series Specifications

Items	M-410iB/160	M-410iB/300	M-410iB/450	
Axes	4	4	4	
Payload (kg)	160	300	450	
Reach (mm)	3143	3143	3130	
Repeatability (mm)	± 0.5	± 0.5	± 0.5	
Interference radius (mm)	674	674	808	
Motion range (degrees)	J1	360	360	
	J2	144	144	
	J3	136	136	
	J4	540	540	
Motion speed ⁽¹⁾ (degrees/s)	J1	130	85	
	J2	130	90	
	J3	135	100	
	J4	300	190	
Wrist inertia (kg-m ²)	J4	78.5	137	196
Mechanical brakes	All axes	All axes	All axes	
Mechanical weight (kg) ⁽²⁾	1940	1940	2430	
Mounting method	Floor (upright)	Floor (upright)	Floor (upright)	
Installation environment	Temperature °C	0 to 45	0 to 45	0 to 45
	Humidity	Normally: 75% or less Short term (within a month): 95% or less No condensation		
Vibration (m/s ²)	4.9 or less			

Notes:

- (1) Maximum linear velocity for M-410iB Series is 2.5 m/s.
- (2) Controller weight of 120 kg is included.

Intelligent Robot Solutions



FANUC Robotics America, Inc.
3900 W. Hamlin Road
Rochester Hills, MI 48309-3253
(248) 377-7000
Fax (248) 377-7362

Charlotte, NC
(704) 596-5121

Chicago, IL
(847) 898-6000

Toronto, Canada
(905) 812-2300

Montréal, Canada
(450) 492-9001

For sales or technical information, call:
1-800-iQ-ROBOT • 1-800-47-ROBOT

Cincinnati, OH
(513) 754-2400

Agascalientes, Mexico
52 (449) 922-8000

Los Angeles, CA
(949) 595-2700

Sao Paulo, Brazil
(55) (11) 3619-0599

marketing@fanucrobotics.com
fanucrobotics.com

Toledo, OH
(419) 866-0788